



# SKE Industries

SKE Industries is mobile bulk materials handling solutions provide in China. And we provide Tracked Conveyor, Radial Telescopic Conveyor, Mobile Ship Loader, Truck Unloader, Link Conveyor, Universal Conveyor and Conveyor Parts.

Site: [www.skecon.com](http://www.skecon.com)

Email: [info@skecon.com](mailto:info@skecon.com)

# KTF Mobile Feeder Conveyor

## Materials:

Coal, Ores, Grains, Fertilizer, Aggregate, Sand, Soils, etc.

## Capacity:

Range from 500 t/h to 2000 t/h

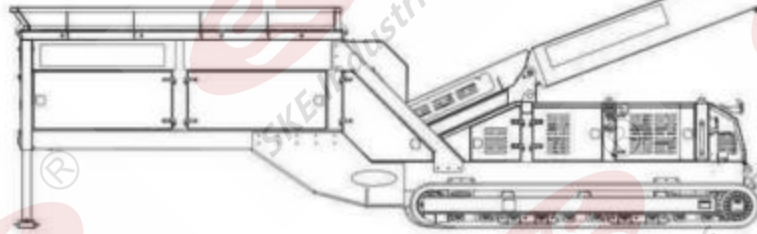

## Applications:

Feeding,

Bulk Materials Stacking,

Loading and Unloading for Wagon and Ships

# Mobile Hopper Feeder Working Dimensions

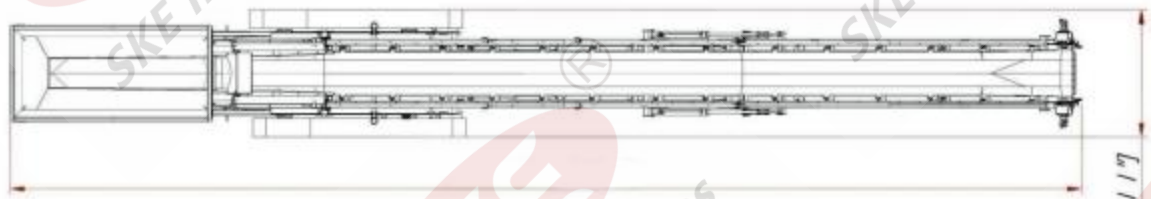
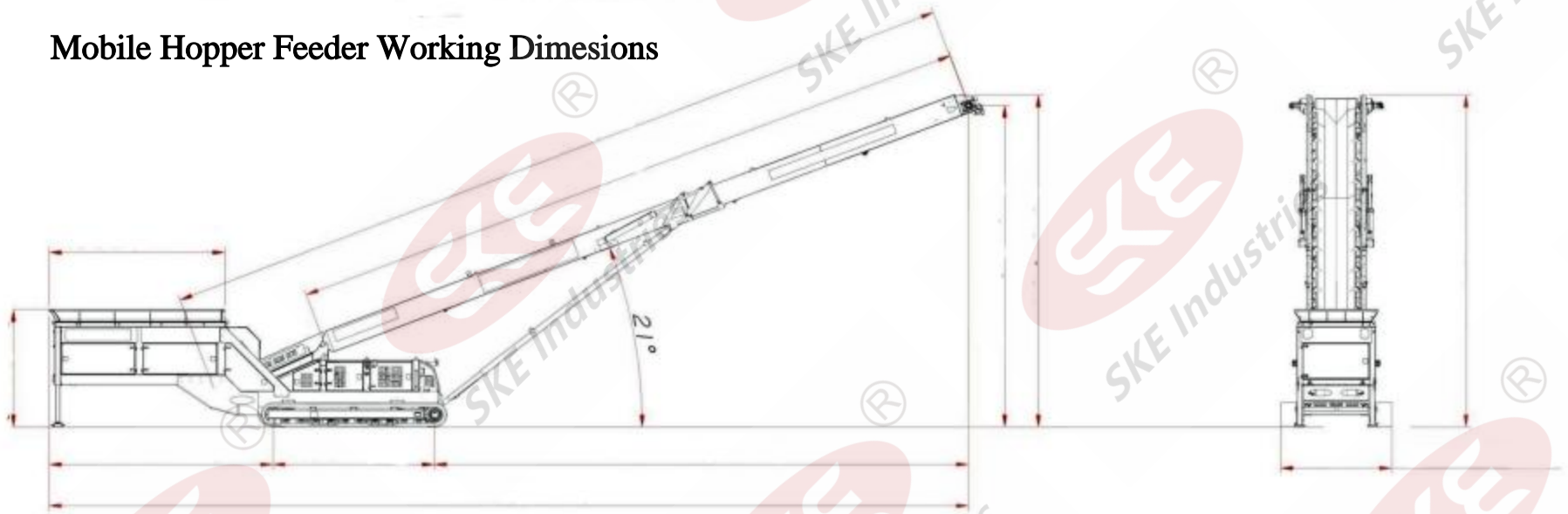

	Metric	Imperial
Conveyor Length	?	?
Machine Working Length (21°)	?	?
Discharge Height (21°)	?	?
Feed in Height (Rear)	?	?
Operating Width	?	?

## Mobile Hopper Feeder Transporting Dimesions

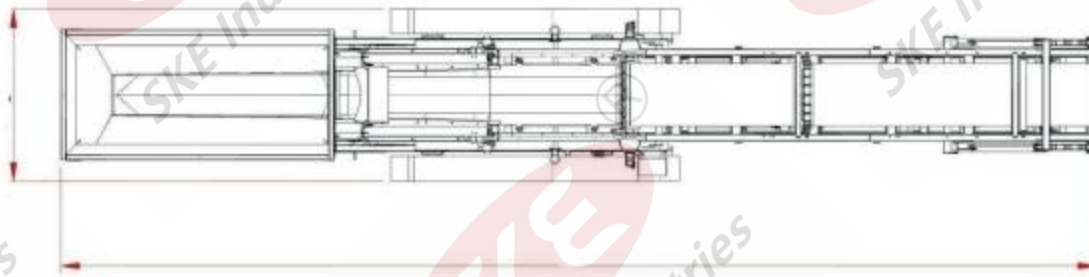
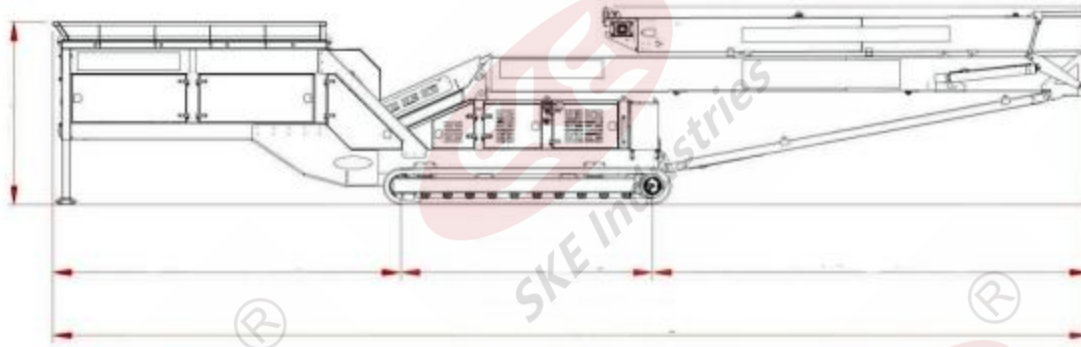

	Metric	Imperial
Transport Length (Head Folded)	?	?
Transport Width	?	?
Transport Height (Head Folded)	?	?
Overall Weight	?	?

Unit can also be transported in 2x 40' High cube containers.